

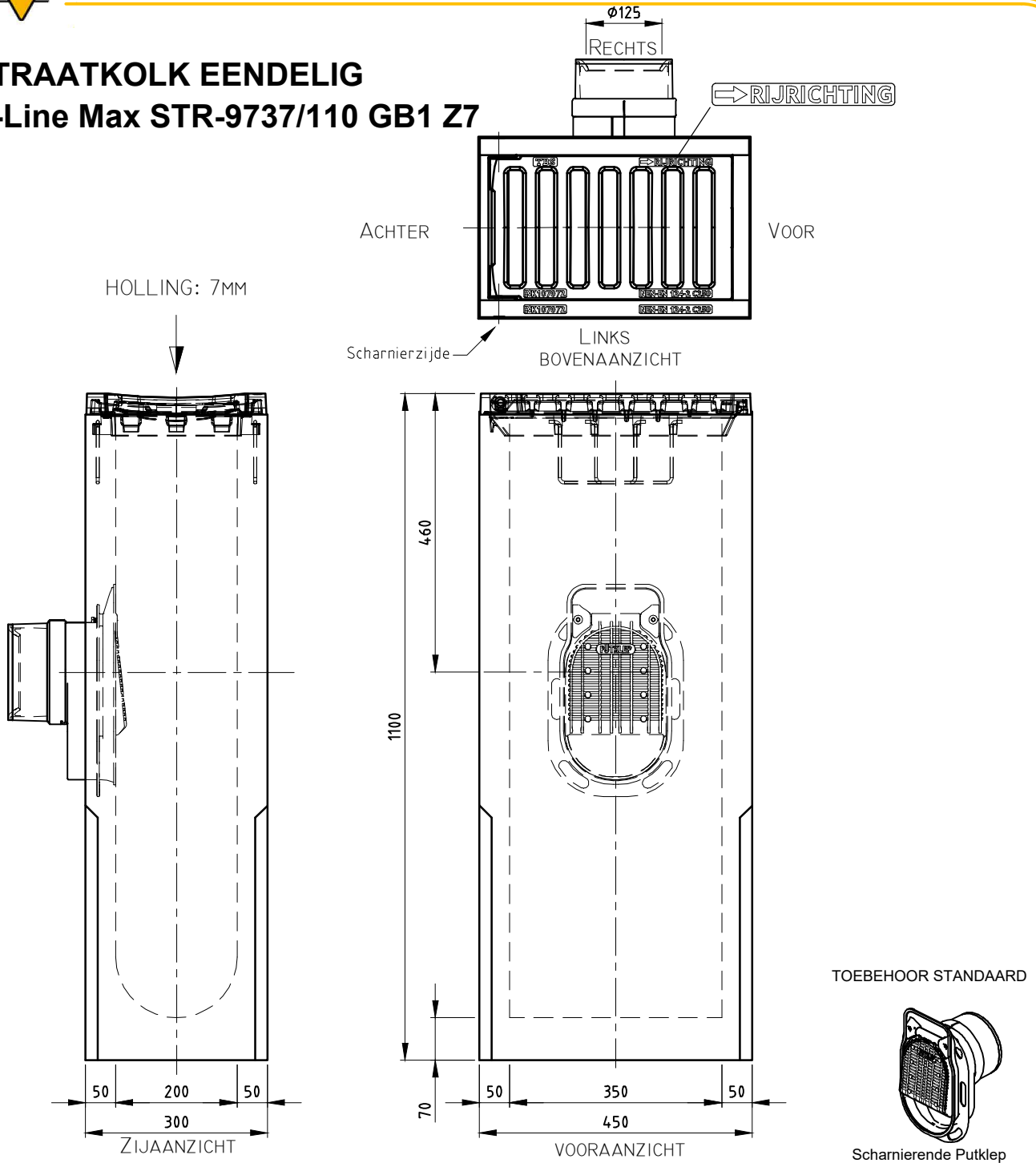





# STRAATKOLK EENDELIG

## Q-Line Max STR-9737/110 GB1 Z7



WIJZIGINGEN VOORBEHOUDEN

Kenmerken	STR-9737/110	Opties
Afmetingen	450x300x1100 mm	
Gewicht	195 kg	
Ø Aansluiting	DN125 FLEX/DN160 FLEX	 
Holling rooster	7 mm	 
Rooster inlaatopeningen	380 cm <sup>2</sup>	
Stankslot	≥40 mm	
Zandvang	32 dm <sup>3</sup>	
Gietijzer kwaliteit rand	GJL	
Gietijzer kwaliteit rooster	GJS	
Keur	KOMO	
Verkeersbelastingsklasse	C250	
Materiaal	beton / GY	
Verankering	d.m.v. wapeningsbeugel	
		Plaatsingsvoorschriften op aanvraag